

# Injury Evaluation and Comparison of Lateral Impacts when using Conventional and Inflatable Restraints

**Tom Green**  
AmSafe Aviation

**Tom Barth**  
AmSafe Aviation

## ABSTRACT

Side Facing Aviation Seat (SFAS) restraint development tests were conducted at the AmSafe dynamic impact facility in Phoenix, AZ. The injury potential for single and multiple occupants of a generic side-facing seat configuration were studied using both a standard three point restraint and a developmental inflatable three point restraint. Evaluation of Anthropomorphic Test Device (ATD) response to various regions of the body using the Hybrid Three (Hybrid III) and European Side Impact dummy (EuroSID-1) ATD were made on a rigid SFAS. The aircraft interiors represented were; an open end seat, a wall barrier, and an armrest barrier. The FAA FAR25.562 longitudinal impact pulse resulted in lateral flailing of the occupant into the barriers when using a standard three point restraint. The ATD head, neck and thorax response using the conventional restraint significantly exceeded those of the airbag restraint for nearly all measures. The occupants using the airbag responded with significantly reduced values for injury risk and satisfy the FAA requirement for non-injurious body-to-body contact in multiple occupant divans.

## INTRODUCTION

This paper reviews the performance of lateral airbag restraint technology developed by AmSafe Aviation. The current aviation regulation for side-facing seats requires an “equivalent” level of protection to forward facing seats. The current FAA policy statement on side-facing seats for transport category airplanes (ANM-03-115-30) recommends using the SID 50<sup>th</sup> percentile male ATD with injury criteria per Federal Motor Vehicle Safety Standard, FMVSS, Part 575.214. The current FAA requirements or SFAS injury criteria consist of the following injury measures and limit values:

<u>Injury Measure</u>	<u>Limit Value/Criteria</u>
Head Injury Criteria (HIC)	$HIC \leq 1000$
Thoracic Trauma Index (TTI)	$TTI \leq 85 \text{ g's}$
Pelvic lateral acceleration	peak $\leq 130 \text{ g's}$
Webbing loads	Force peak $< 1750 \text{ lbs}$
Body-to-body contact	No Injury (subjective)
Neck injury	mentioned (not defined)

Limited understanding of body-to-body contact injury has resulted in a policy that no body-to-body contact is allowed for the head and torso regions, while incidental contact of the arms and legs is acceptable. The neck injury requirement has yet to be defined and is the subject of current FAA research. A preliminary FAA neck injury criterion is evaluated using the Hybrid III test dummy.

A neck injury criterion for forward (longitudinal) impacts has been established within FMVSS 208 using the Hybrid III ATD for occupants of passenger automobiles. However, requirements for lateral neck injury are not regulated for automotive or aviation occupants. The biofidelic deficiencies of the Hybrid III ATD for lateral impact conditions are well documented. The stiffness of the neck and spine are not representative of the human subject. The EuroSID-1 provides a more realistic representation of the head flailing, but lacks the ability to measure upper neck loads. Use of the Hybrid III test dummy in this test series was due to its availability, its durability and to quantify the step change in performance according to restraint technology. The response of the Hybrid III upper neck loading is reported in the primary context of comparison between the standard restraint and the airbag. The results are also measured against the existing FMVSS 208 Fore/Aft neck injury criteria in addition to the FAA proposed “Soltis Lateral Criteria.” Steve Soltis is the FAA research scientist who has proposed a side-facing aircraft seat neck injury criteria based upon modeling and literature research.

Recent automotive advances for lateral impact safety have resulted in upgrades to side impact specific ATDs. The European Union has been principal in issuing side-facing seat assessment protocols and biomechanical limits that become regulation. The first European Side Impact regulation in the late nineties was followed with the non-governmental European New Car Assessment Program (EuroNCAP). Further automotive side-facing impact research in the United States has led to new proposals for upgrading the existing US FMVSS 214

law. The second European Side Impact dummy (ES-2) has been recommended by NHTSA for the FMVSS 214 upgrade for automotive side impact applications and will likely be included in revised FAA policy for side-facing seats. These anticipated FAA side-facing seat criteria are provided below in Table 1.

This paper includes evaluations of a variety of measures, both regulated and developmental; using the current FAA approved Hybrid III and EuroSID-1 ATDs.

Criteria	Limits
HIC36	<1000
Rib Deflection, (mm) (inches)	35-44 1.38-1.73
Lower Spine Resultant (T12), (g)	82
Abdominal Force, Sum Fy (N) (lbs)	2,400-2,800 540-629
Pubic Symphysis, (N) (lbf)	6,000 1,349
Neck Injury, Nij Lateral	Proposed Nij < 1
Body-to-body contact (contact between the head, pelvis, or shoulder area of adjacent ATD).	Unacceptable
Shoulder Loads	< 7784 N <1750 lbs
Occupant Retention	Prevent ATD from translating beyond end of seat.

**Table 1: Anticipated FAA Side Facing Seat Injury Criteria.**

**OBJECTIVES**

The objective of this research was to investigate the injury potential for single and multiple occupants in side-facing seats and evaluate assessment criteria defined in the FMVSS 214 upgrade comparing standard and airbag restraint systems. The airbag restraint system is referred to as the AmSafe Aviation Inflatable Restraint (AAIR). See Table 1 for a summary of the evaluated injury criteria.

These same restraints have also been provided to support FAA research testing at the Civil Aero Medical Institute (CAMI), the results of which will be published in the FAA report; DeWeese R, Moorcroft D, Green T, Philippens MMGM, *Assessment of Injury Potential in Aircraft Side Facing Seats Using the ES-2 ATD*, FAA Office of Aerospace Medicine, Washington DC (In Press).

**METHOD**

A series of 12 dynamic sled tests were conducted at the AmSafe Aviation test facility in Phoenix, Arizona. All testing was in the sideward facing condition. Table 2 summarizes by test number, the seat configuration, restraint system, ATD evaluated, and impact data evaluated in this test series. Eight tests were conducted with single occupants and four tests with dual occupants.

Seat Position	Restraint Type	Test No.	ATD Type	Test Pulse	Min. Vel.
				g's	ft/s
Middle	Std	F0380	HIII	17.2	45.1
Middle	AAIR	F0379	HIII	16.5	44.6
Middle	Std	F0287	ES-1	16.9	45.6
Middle	AAIR	F0331	ES-1	17.4	45.1
Middle	Std	F0290	ES-1	17.9	45.0
Middle	AAIR	F0332	ES-1	17.5	45.1
Wall	Std	F0290	HIII	17.9	45.0
Wall	AAIR	F0332	HIII	17.5	45.1
Wall	Std	F0289	ES-1	17.0	45.3
Wall	AAIR	F0293	ES-1	16.5	45.2
Wall	Std	G0236	ES-1	15.8	45.1
Wall	AAIR	G0235	ES-1	16.6	45.0
Armrest	Std	F0380	ES-1	17.2	45.1
Armrest	AAIR	F0379	ES-1	16.5	44.6
Armrest	Std	F0386	HIII	16.8	45.0
Armrest	AAIR	F0388	HIII	16.6	44.5

**Table 2: Side Facing Aircraft Seat Test Matrix with Impact Data**

**IMPACT CONDITIONS**

Impact conditions were in accordance with 14 CFR 25.562, requiring a minimum target velocity of 44 ft/sec and a 16-G peak triangular pulse. This symmetric, triangular pulse reaches the peak acceleration at 90ms and has duration of 180ms. Data contained in this report conforms to SAE AS8049 Rev. A, SAE J211/1 March 1995. Impacts were horizontal with no yaw angle between the seat and the impact vector.

**TEST FIXTURE AND SEATING POSITIONS**

The rigid side-facing seat was derived based upon an industry survey of side-facing divan dimensions. The test seat is a three place divan (72 inches long) with four-inch thick cushions. The cushions are made from four-inch thick DAX 47 (green) foam, 2.1 lb density, covered with upholstery grade leather and attached to the seat bottom and back with three, two-inch wide strips of

Velcro. The test fixture is shown in Figures 1 and 2. The aircraft interior was represented by either a rigid wall or armrest, as shown in the figures. All testing was conducted in seat positions B (middle) and C (next to barrier). Dimensions are in inches. Table 2 provides a list of the test configurations, test sequence numbers, restraint type, dummy type, and actual impact peak G and velocity change.

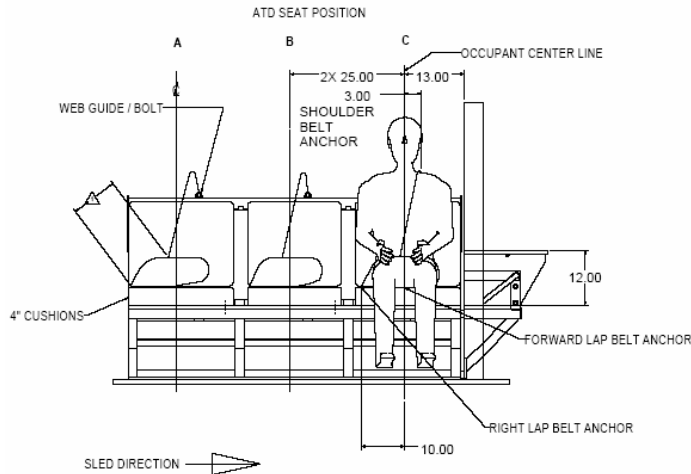

**Figure 1: Rigid Test Fixture, Front View**

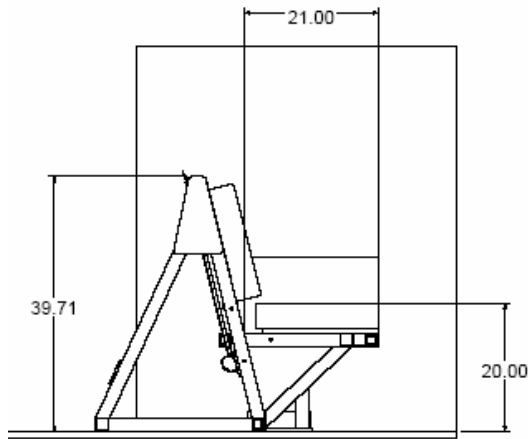

**Figure 2: Rigid Test Fixture, Side View**

## RESTRAINT SYSTEMS

The conventional or standard restraint consisted of an AmSafe three-point system with a locking inertia reel and a push button buckle. The buckle was located above the right thigh and includes a manual adjuster and attachment point for the detachable shoulder harness. The inertia reel locks with a webbing pay out of 1.25G, with a tolerance of 0.25G.

The airbag restraint was based on the same conventional three-point restraint as described above, but with the addition of AAIR components. The AAIR incorporated a tubular inflatable airbag which replaced a

section of the shoulder strap. The Seatbelt Airbag Assembly (SAA) consists of the standard restraint with additional inflatable, protective cover and gas delivery hose. A stored gas cylinder is the Inflator Assembly which provides a source to inflate the airbag. The inflator assembly mounted under the seat uses an inert gas mixture of argon and helium. Upon receiving a signal, a pyrotechnic squib housed within the inflator bursts a stainless steel diaphragm, allowing the gas to travel through a delivery hose and to the airbag. The initiation signal is provided by the Electronics Module Assembly (EMA). The EMA contains a firing circuit, a lithium battery, and a mechanical crash sensor. The crash sensor is tuned to activate given a threshold velocity change. The threshold parameters are well above flight transients or vibrations such that inadvertent deployment does not occur, yet allow the airbag to inflate for impacts which could cause injury to occupants. The SAA, Inflator Assembly, and EMA are all electrically connected by a cable assembly. The cable assembly includes an activation switch in the buckle, which disables the system when not buckled.

## INJURY ASSESSMENT

The injury potential for single and multiple occupants in side-facing seats were evaluated comparing standard and airbag restraint systems. Performance using the Hybrid III and the EuroSID-1 50% male are evaluated based upon the assessment protocols and biomechanical limits of each test device. The EuroSID-1 was used to measure the assessment criteria defined in the FMVSS 214 upgrade. The EuroSID-1 is the predecessor to the EuroSID-2 ATD and is currently mandated for use by the European Union for automotive side-facing testing, EU 96/27/EC. See Table A1 which provides a summary of current and proposed injury criteria.

Head injury was estimated for all test occupants by HIC analysis. HIC was calculated after initial impact, as called for by aviation regulations. HIC after initial contact only evaluates impacts that involve head contact, and limits the evaluation period to the time of initial head contact until the end of the test event. In cases with no impact the HIC unlimited is used. HIC unlimited is the maximum HIC determined across the total event duration. On tests with the inflatable restraint, HIC was calculated from head contact with the airbag. Head contact during impact causes a spike in acceleration which defines the HIC window. No manual manipulation of the HIC window was required.

Automotive research has shown that the currently regulated TTI and Pelvic acceleration criteria to be poor predictors for measurement of injury risk. The proposed FMVSS 214 upgrade recommends thoracic criteria of rib deflection, abdominal load and lower spine acceleration which reflect improvements in estimating the risk for thoracic injury due to lateral impact.

The Hybrid III was used primarily due to its availability and ability to measure neck loads. The estimate of risk for neck injury in forward auto crashes is defined per FMVSS 208 using the Hybrid III. This neck injury criterion defines a limit for upper neck tension and compression as well as criteria that evaluates the combined effect of neck fore/aft bending moment and tension, called  $N_{ij}$ .

$$N_{ij} = F_z/F_{zc} + M_y/M_{yc} \quad \text{Fore/Aft}$$

Building upon automotive research defining the Fore/aft  $N_{ij}$  criteria, the FAA has proposed a lateral neck injury criteria, lateral  $N_{ij}$ , which replaces moment about the y-axis,  $M_y$ , with lateral moment about the x-axis,  $M_x$ .

$$N_{ij} = F_z/F_{zc} + M_x/M_{xc} \quad \text{Soltis lateral}$$

The neck injury response reported herein is based upon both the fore/aft  $N_{ij}$  of FMVSS 208 and the proposed FAA lateral neck injury criteria, lateral  $N_{ij}$ . In addition the FAA is proposing the following limits for tension, compression and lateral neck shear.

- Fz (tension limit) = 940lbf
- Fz (compression limit) = 900lbf
- Fy (lateral neck limit) = 696lbf

The appropriate critical values for lateral impact neck injury are not well established at this time and are the subject of research. The FAA is ardently working with a number of research organizations to develop injury criteria that will be applicable for occupants of sideward facing aircraft seats in order that sideward facing seat might be certified to an equivalent level of safety.

The upper neck forces reported in this report are normalized to the occipital location. Table 3 provides a summary of the neck injury coefficients used in the Fore/aft and Lateral  $N_{ij}$  analysis. The results provide performance insight for likely criteria expected to be recommended in FAA side-facing regulatory policy.

FMVSS 208				
Coefficients	Fore / Aft		$N_{ij}$	
Myc (flexion)	2748	in-lb.	310	Nm
Myc (extension)	1200	in-lb.	136	Nm
Fzc (tension)	1530	lb.	6.81	kN
Fzc (compression)	1385	lb.	6.16	kN
FAA- Soltis Proposal				
Coefficients	Lateral $N_{ij}$ –preliminary			
Mxc (left)	530	in-lb.	60	Nm
Mxc (right)	530	in-lb.	60	Nm
Fzc (tension)	1530	lb.	6.81	kN
Fzc (compression)	1385	lb.	6.16	kN

**Table 3: Summary of Neck Injury Criteria,  $N_{ij}$  Coefficients**

Another indicator of risk for neck injury is the Injury Assessment Reference Values (IARV) for the 50<sup>th</sup> percentile male. An IARV is the level of a surrogate's response that corresponds to the desired lower bound of occupant protection and the upper bound of injury risk. These values for forward impact directions are well accepted, while the injury estimates for lateral force and moments are not well defined. The IARV limits listed are:

For 50th % males, the IARV values are:

- Upper neck flexion (+ $M_y$ ) 190 Nm (1682 in-lb)
- Upper neck extension (- $M_y$ ) 57 Nm (504 in-lbf)
- Neck tension (+ $F_z$ ), 3.3 kN (742 lbf)
- Neck compression (- $F_z$ ) 4 kN (899 lbf)

The force criteria are also separated by duration.

Short duration loading ( $t < 35$ ms) the values are:

- Neck tension (+ $F_z$ ) 2.9 kN (652 lbf)
- Neck compression (- $F_z$ ) 1.1 kN (247 lbf)
- Fore-aft shear at the Occipital Condyle 1.5 kN (337 lbf)

The long duration values are:

- tension 1.1 kN (247lbf),  $t > 45$ ms
- compression 1.1 kN (247lbf),  $t > 30$  ms
- shear 1.1 kN (247lbf),  $t > 45$  ms

(Weerappuli, 2005; Mertz 1993)

## RESULTS

The complete data summary is provided in the appendix of this paper and includes summary tables for the response measures for easy comparison. They are organized first according to ATD type and then to seating location.

The calculated HIC values indicate that head injury is a significant risk in all seating positions using the standard restraint. The lateral flail of these occupants in the wall and middle seat positions allowed head contact with adjacent wall and seat structure. In the armrest position the EuroSID-1 exhibited a long duration (40ms) of head acceleration above 40 g's. The Hybrid III in the armrest position exhibited a duration of 30ms above 40g's yet was the only exception with no impact (HIC <1000). The EuroSID-1 ATD in the armrest position gives an indication of the response due to inertia loading. See Figures 7 and 8. Figure 3 gives a summary view of the range of HIC values across the test matrix. Note the reduced values for HIC when using the inflatable restraint (AAIR).

compression (-Fz) as the head rotates and strikes the wall.

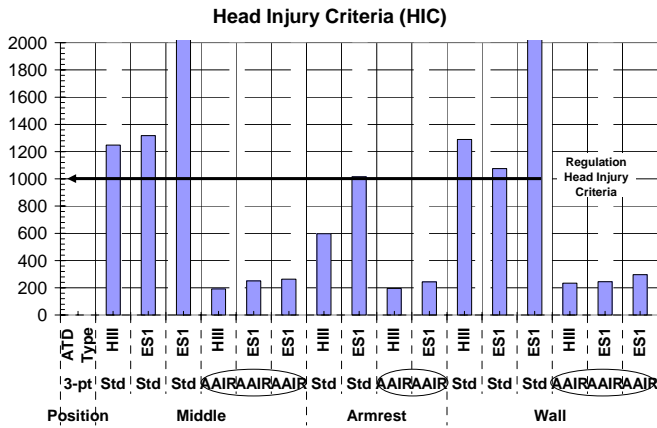

**Figure 3: Summary of HIC Analysis – Seat Position and Restraint Comparison**

Only in the wall position did a measurement indicate risk for injury to the thoracic region. The Hybrid III chest acceleration and the EuroSID-1 upper rib deflection using the standard restraint exceeded the lower limit criteria. The inflatable restraint was effective in reducing the severity of head and thoracic impact with the adjacent wall and armrest.

While none of the measurements indicated a significant risk for injury due to web load or to the spine, abdomen or pelvis region for this group of seat configurations, the inflatable restraint significantly reduced these values in all seating locations.

Upper neck response exceeded the IARV values (based for forward impact), in the middle seat position using the standard restraint. Test F0380 resulted in an upper neck load, Fz = 750lbf, this parameter was reduced to 248lbf with the inflatable restraint.

Based upon the FAA proposed “Soltis Lateral Criteria”, the greatest risk for neck injury was found for occupants in the armrest positions using the standard restraint. The values for lateral Nij exceed the proposed lower limit by four fold (4.04) in this position. Use of the inflatable restraint in the armrest and wall position also exceeds the 1.0 limit, to a lesser degree (1.33). In the wall position the type of restraint has little effect upon the lateral Nij response, thus it is not clear if this lower limit represents a risk for injury. Further research into the injury onset region is needed for lateral impact. Table 4 provides a summary of the peak values generated from the neck injury criteria, Nij analysis.

Figure 4 provides a summary of the peak upper neck loads by resultant component and seating position. A significant reduction in upper neck load is observed when using the inflatable restraint system (AAIR). In all cases Fz is the predominant component of the resultant. In the wall position the neck experiences a large

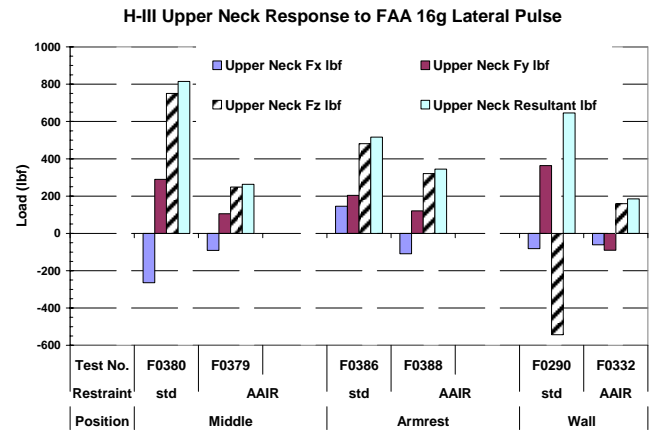

**Figure 4: Hybrid III Upper Neck Load Response.**

A summary of peak upper neck moments is provided in Figure 5. A significant reduction in upper neck moments is observed when using inflatable restraint system in the middle and armrest positions. The major contributor to the resultant is Mx when using the standard restraint. When using the inflatable restraint (AAIR), My becomes the leading contributor. The fore/aft Nij analysis indicates My to be non-injurious. In the wall position, the Hybrid III upper neck experiences a longer duration of Mx with the inflatable restraint compared to the standard restraint. This is the result of airbag reacting against the wall and the torso sliding laterally under the airbag. Further details of the neck loading phenomena are provided in following sections defined by the seat position.

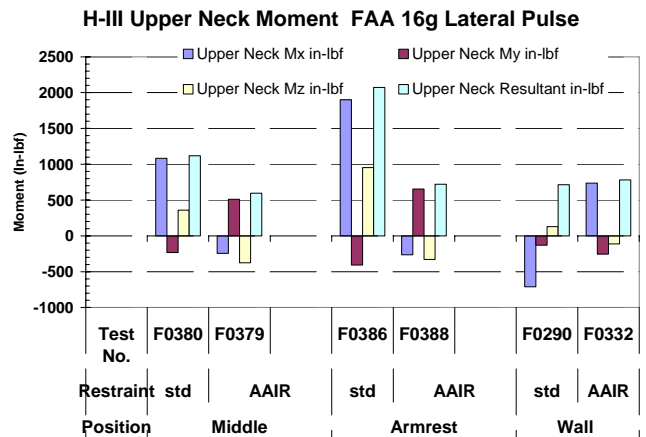

**Figure 5: Hybrid III Upper Neck Moment Response**

The upper neck in the armrest position produced the highest moments in Mx, while the middle position produced the greatest tension load in Fz.

Hybrid III Upper Neck Response			Peak Values - Neck Injury, $N_{ij}$ Analysis	
Seat Position	Type Restraint	Test Number	Fore/Aft	Lateral
Side Facing	3-point		FMVSS 208	Soltis Criteria Proposed
Middle	Std	F0380	0.59	2.67
Middle	AAIR	F0379	0.26	0.51
Armrest	Std	F0290	0.50	4.04
Armrest	AAIR	F0332	0.33	1.33
Wall	standard	F0386	0.40	1.37
Wall	AAIR	F0388	0.28	1.38

**Table 4: Results of Hybrid III Upper Neck  $N_{ij}$  Analysis.**

The FAA proposed neck injury criteria for lateral impact is heavily weighted toward the neck moment response. The response of neck tension has minor affect. While research has shown neck tension to be a strong predictor for injury in fore/aft impacts, it has also been shown that the Hybrid III responds with greater magnitudes of occipital condyle forces and moments than human subjects. Future research into the level of lateral neck injury onset will enlighten this issue.

#### ARMREST POSITION

The armrest configuration was tested in sequence number F0379 with the AAIR, and in F0380 with the conventional restraint. In both cases the Hybrid III occupied the middle seat while the EuroSID-1 was next to the armrest.

Figure 6 provides a sequence of images from the front view of the two place armrest test. The flailing of the head over the armrest is shown on the right side in the third frame of Figure 6. This position presents the greatest risk for injury due to inertia loading to the head and loads to the neck.

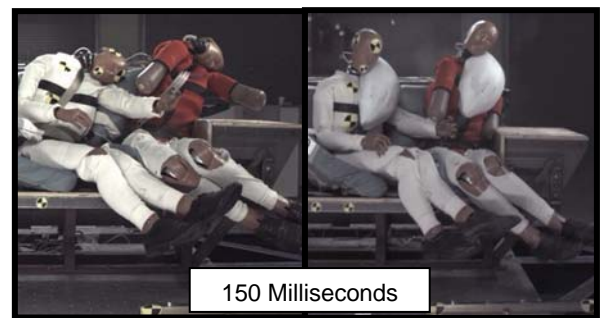
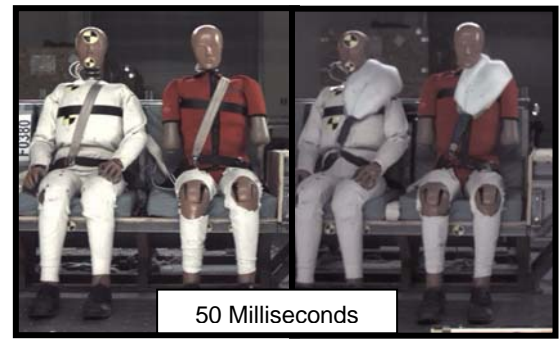

**Figure 6: Armrest Comparison, 50-150ms**

Figure 7 compares the head resultant acceleration for the armrest seat with EuroSID-1 occupant using the conventional versus AAIR restraint (test F0379 and F0380 respectively). EuroSID-1 HIC without the AAIR is 1016, and with the AAIR HIC equals 244. The peak accelerations were 65G and 31 G, respectively.

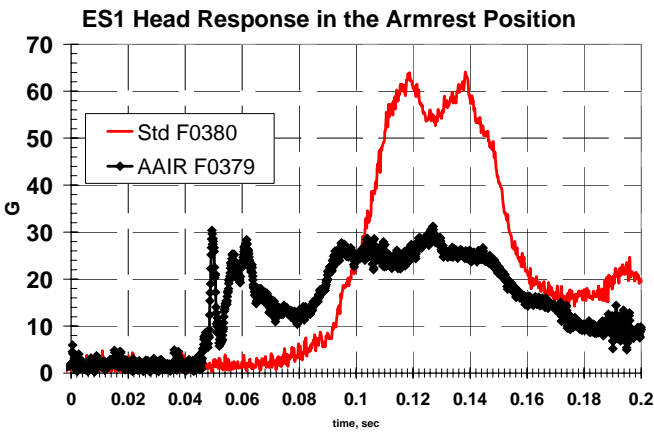

**Figure 7: EuroSID-1 Head Resultant Acceleration in the Armrest Position, Comparison of Standard vs. AAIR**

The standard restraint EuroSID-1 occupant sustains head acceleration over 50 gs for over 30ms. The second peak is due to a strike on the ATDs own shoulder as the head swings around.

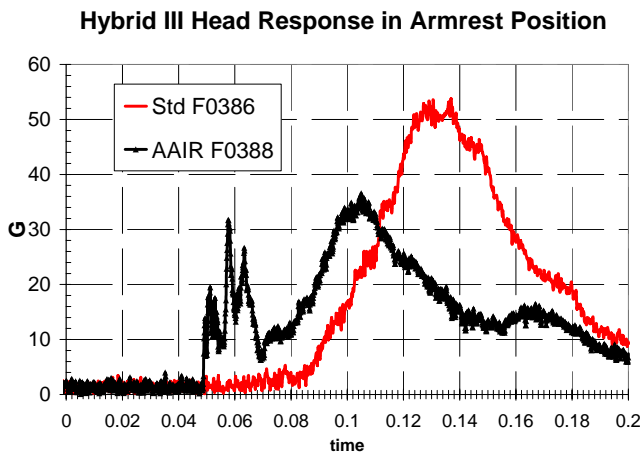
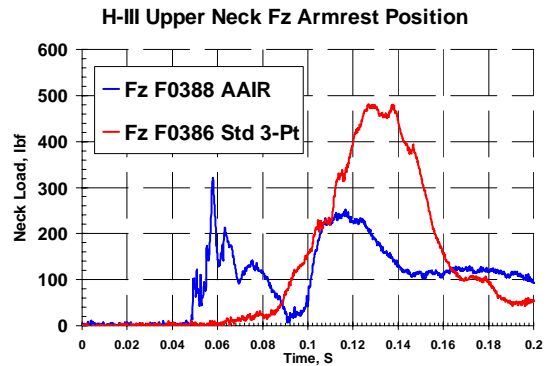

**Figure 8: Hybrid III Head Response in the Armrest Position, Comparison of Standard vs. AAIR**

The HIC calculation did not exceed the limit for the Hybrid III occupant and head strike is not a major concern for this seating configuration (Figure 8). The long duration of high acceleration is of potential concern for brain injury, a mechanism of injury currently under research yet not fully understood. FAA research presented at the 2006 SAE GATC conference reported that this seating condition presents a high risk for brain injury as measured with the 9-array SIMon: simulated injury monitor. When restrained with the AAIR System, the peak head acceleration is reduced to 31g's, a major improvement for potential inertial head injury.

The greatest risk for neck injury is in the armrest position, based upon the Hybrid III lateral neck injury,  $N_{ij}$  response. The upper neck in the armrest position produced the highest moments in Mx. The proposed

lateral load criterion,  $N_{ij}$ , is heavily weighted to the Mx variable. See Figures 9 through 11 for a visual perspective of  $N_{ij}$  relationship with load and moment.



**Figure 9: Hybrid III Upper Neck Fz Response in the Armrest Position, Comparison of Standard vs. AAIR**

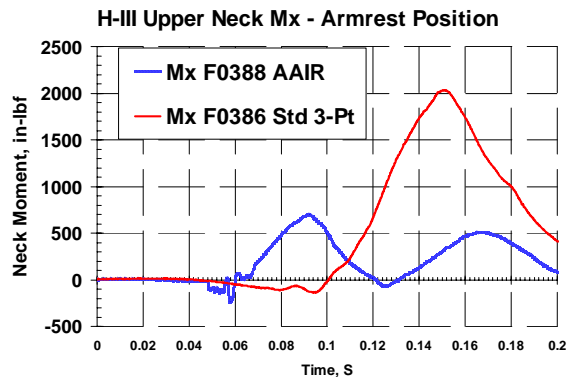

**Figure 10: Hybrid III Upper Neck Mx Response in the Armrest Position, Comparison of Standard vs. AAIR**

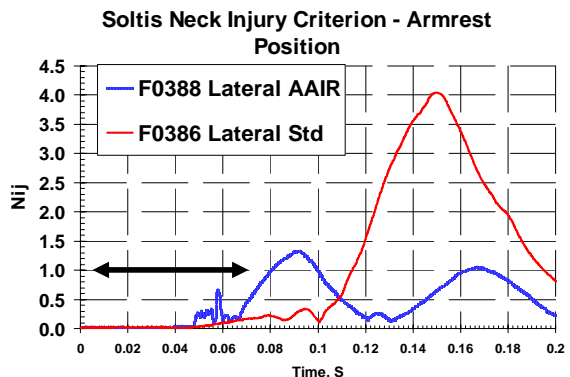

**Figure 11: Hybrid III Neck Lateral Load Criteria Response in the Armrest Position, Comparison of Standard vs. AAIR**

The performance of both restraints types with respect to the FAA proposed lateral neck injury criteria,  $N_{ij}$ , over the event duration is shown in Figure 11. The standard restraint lateral  $N_{ij}$  response peaks at 4.0 while the AAIR peaks at 1.3.

Results of the EuroSID-1 upper and lower spine are shown in Figure 12. The performance of the AAIR reduces the spine lateral acceleration to less than 35 g's.

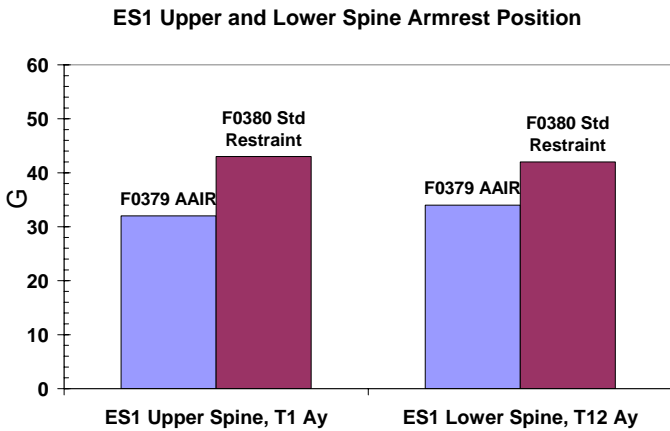

Figure 12: Upper and Lower Spine Acceleration, Ay

WALL POSITION – DUAL OCCUPANTS

The current regulatory policy does not allow any contact between the head and torso of the occupants. Interiors using conventional restraints are unable to allow the wall position of side-facing divan to be occupied due to concerns of body-to-body contact. Figures 14 and 15 confirm this impact as illustrated.

The wall seating configuration is tested in sequence number F0290 with the conventional restraint and in F0332 with the AAIR restraint. In both cases the EuroSID-1 occupied the middle seat while the HIII was next to the wall. This seating arrangement was made to exhibit the dummy with greatest flail. The wall configuration is representative of typical divan style configurations commonly used in current business jet applications.

Loading of the neck against the wall is a complex event. As the head impact the wall with the standard restraint, the neck is in compression. With the AAIR the head is protected by the bag with the neck experiencing equal level of moment with a longer duration. Figure 13 shows the comparison of Nij analysis comparing restraint type. The AAIR produces an equivalent peak value for Nij, but the duration of moment load is evident in the Nij plot. While the AAIR provides head protection advantage, the level of neck protection is undetermined in this case due to the lack of biofidelic properties of the Hybrid III neck.

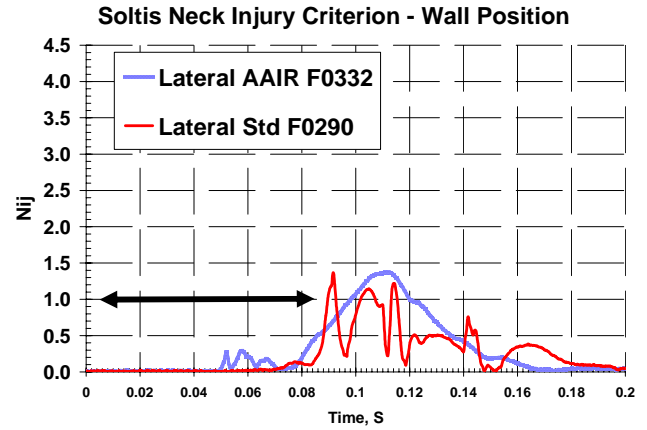

Figure 13: Hybrid III Neck Lateral Load Criteria Response in the Wall Position, Comparison of Standard vs. AAIR

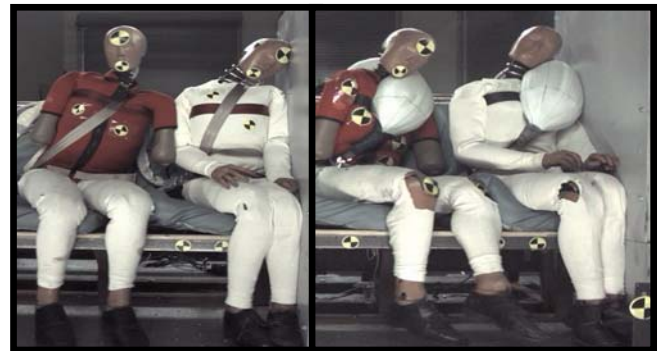

Figure 14: Wall Comparison, 120ms

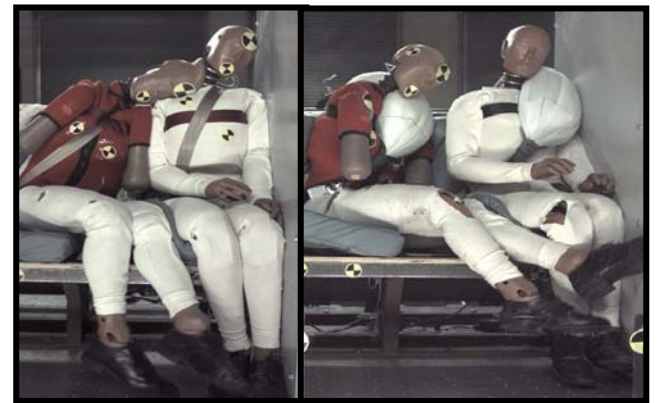

Figure 15: Wall Comparison, 150ms

The head of the middle occupant strikes the shoulder of the occupant against the wall at about 150ms into the event as shown in the left side of Figure 15. The HIC was 2569 resulting from the impact with a head acceleration peak of 353g. The same configuration tested with the AAIR resulted in no contact between the occupants, as shown in the right side of Figure 15. The

head of the middle occupant using the AAIR had a HIC of 263 with a peak head acceleration of 44g.

The chest accelerations for the occupant seated next to the wall spike to 102g in the Hybrid III using standard restraints in test F0290. This compares to the same condition with the AAIR in test F0332, which had a maximum chest acceleration of 33g.

### WALL POSITION – SINGLE OCCUPANT

The single occupant wall position was tested in sequence number F0289 and G0236 with the conventional restraint and sequence F0293 and G0235 with the AAIR restraint. In both cases the EuroSID-1 occupied the seat next to the wall, positioned as shown in Figure 1. The head and thoracic regions pose the greatest risk for injury in this position using the standard restraint. Figure 16 shows the resulting rib deflection in the wall position using standard restraints. The rib deflection response against the wall with the inflatable restraint was not detectable.

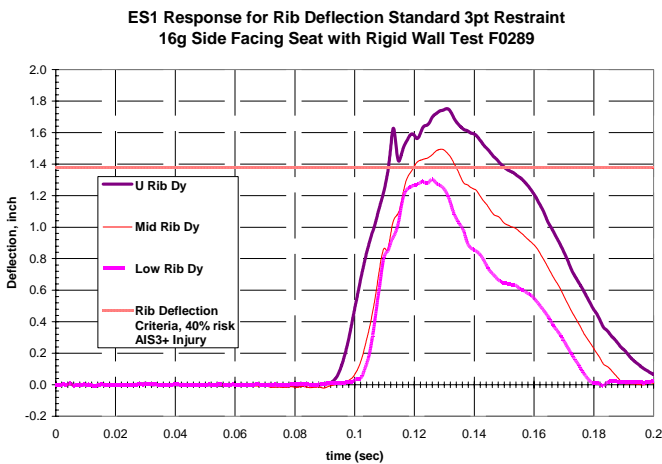

**Figure 16: Rib Deflection in the Wall Seating Position**

The EuroSID-1 represents a 50<sup>th</sup> percentile adult male without lower arms. The thorax consists of three, identical rib modules. Each module consists of a spring and damper design. Both the armrest and wall position pose a threat as the ATD impacts the barrier. Limit criteria for aviation are under consideration. The lower limit rib deflection criterion is 1.38 inches of deflection, corresponding to a 40% risk of level 3 Abbreviated Injury Scale (AIS) injury.

The pubic force in this series was reduced from 875 to 451 lbs using the airbag as measured in the EuroSID-1 ATD. In one test (F0289) against the wall the pubic force was measured at 1121 lbf. The injury criterion for pubic force is 1349 lbf.

### MIDDLE SEAT – SINGLE OCCUPANT

Evaluation of the middle seat position consisted of six sled tests. Four tests are multiple occupant configurations against a wall and armrest. The single occupant test sequence numbers are F0287 (ES-1) using the conventional restraint and F0331 (ES-1) using the AAIR restraint. The multiple occupant tests conducted made use of the H-III in both seating positions. In one test using the conventional restraint (F0290, ES-1) the occupant interacts with the head striking the shoulder of the adjacent occupant (H-III). In test F0380 the (ES-1) dummy strikes the seatback.

#### H-III Head Response in Middle Position

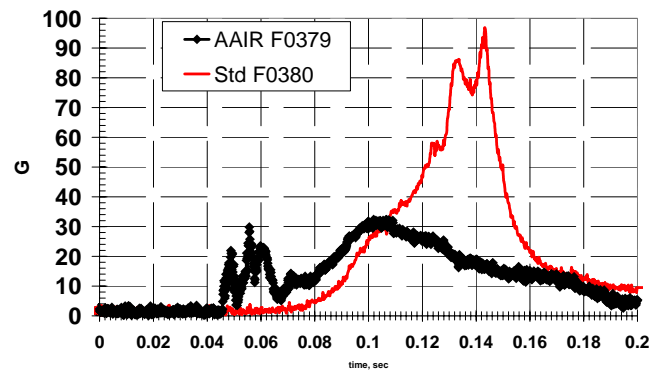

**Figure 17: Hybrid III Head Response in the Middle Position, Comparison of Standard vs. AAIR**

In addition to head impact (HIC), the main risk for injury in the middle position is exposure to high head accelerations for long durations (figure 17) and high neck loads. The H-III with the standard restraint experienced head acceleration beyond 60 g's for a duration greater than 20 milliseconds. The occupant with the AAIR does not exceed 32 g's of resultant head acceleration for any duration. The reduced head acceleration demonstrates a potential for reduction in inertia loading to the brain.

The Hybrid III upper neck load in tension (F0379) is at its maximum ( $F_z=750$  lbf) in the middle position when using standard restraints. Test F0380 demonstrates effective use of the AAIR System to reduce upper neck force and moments by more than 50% in the middle seat position. Figure 18 illustrates the performance of both restraints types with respect to the FAA proposed lateral neck injury criteria,  $N_{ij}$ , over the event duration. The standard restraint lateral  $N_{ij}$  response, peaks at over 2.5 while the AAIR does not exceed 0.5. The upper neck moment measured in test F0380 peaked at 1083 in-lbf.

Soltis Neck Injury Criterion - Middle Position

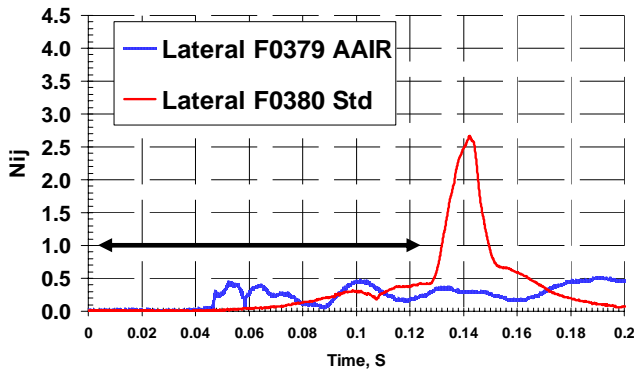

Figure 18: Hybrid III Neck Lateral Load Criteria Response Middle Position, Comparison of Standard vs. AAIR

The Hybrid III resultant chest acceleration is peaked at 60 g's with the standard restraint. The FMVSS 208 criteria (see appendix table A1), a forward facing limit, limits chest acceleration (Ax) to 60 g's in the x-axis. Use of the inflatable (F0379) reduced the resultant chest acceleration to 39 g's. The Ax went from 21 to 16 g's and Ay went from 43 to 26 g's with the inflatable restraint. See Resultant chest accelerations presented in figure 19 for the middle position.

H-III Resultant Chest Acceleration Middle Position

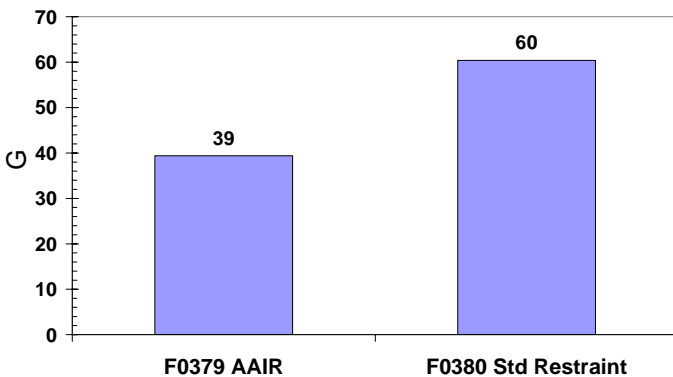

Figure 19: Hybrid III Resultant Chest Acceleration, Middle Position, and Comparison of Standard vs. AAIR

**CONCLUSION**

This test series provides evidence that the existing injury criteria currently in use by the FAA does not provide occupants of sideward facing aircraft seats an equivalent level of safety as forward facing seats. Use of the EuroSID ATD would be a big advancement in improving lateral impact safety.

For all seating positions evaluated, HIC analyses indicate the greatest risk for head injury using the standard restraints. In the middle and armrest positions lateral flail and inertia loading to the head was observed above 50 g's using the Hybrid III and EuroSID-1 ATD's. For all seating positions using the inflatable restraint (AAIR) not one exceeded 50 g's and a significant reduction was measured for the risk of injury to the head.

In the wall position, using standard restraints, the EuroSID-1 ATD rib deflection exceeds the lower limit of the NHTSA proposed 214 criteria. When using the AAIR System the rib deflection response was not detectable.

For injury criteria which do not exceed injurious limits, the parameters are reduced when compared using the AAIR System vs. the standard three-point restraint. The pubic symphysis peak force (PSPF) criterion is approached, but not exceeded, and is reduced by 65% in the wall position. Lower spine accelerations are reduced by 35% in the middle seat and abdomen loads in the armrest position are reduced by 80% with the AAIR System.

This test series shows evidence, using the Hybrid III ATD restrained with a standard restraint, that upper neck peak loads exceed the Injury Assessment Reference Value (IARV) in the middle seat.

While neck loads and moments are significantly reduced with the AAIR system, the proposed FAA lateral Nij criteria were exceeded in all locations except the middle seat position with and without the AAIR restraint.

**REFERENCES**

1. Duma, Crandall, Rudd, Kent. Small female head and neck interaction with a deploying side airbag. Accident Analysis and Prevention 35 (2003) 811-816.
2. Yoganandan, Pintar. Responses of side impact dummies in sled tests. Accident Analysis and Prevention 37 (2005) 495-503.
3. Horsch, Horn, McCleary. Investigation of inflatable belt restraints. Biomedical science dept., General Motors Research Labs 912905
4. Nusholtz, Domenico, Shi, Eagle. Studies of neck injury criteria based on existing biochemical test data. Accident Analysis and Prevention 35 (2003) 777-786.
5. Voo, Yoganandan, Pintar, Kleinberger, Eppinger. Biomechanical impact tolerance characteristics of the human neck. National Highway Traffic safety administration, United States. Paper Number 98-S7-O-05.

6. DeWeese R, Moorcroft D, Green T, Philippens MMGM. *Assessment of Injury Potential in Aircraft Side Facing Seats Using the ES-2 ATD*. FAA Office of Aerospace Medicine, Washington DC (In Press).
7. Soltis, Frings, Gowdy, DeWeese, Van Hoof, Meijer, Yang. Development of side impact neck injury criteria and tolerances for occupants of sideward facing aircraft seats.
8. Soltis, S.J., "An Overview of Existing and Needed Neck Impact Injury Criteria for Sideward Facing Aircraft Seats". The Third Triennial International Aircraft Fire and Cabin Safety Research Conference, Atlantic City, NJ, October 22-25, 2001.
9. Bandak, Zhang, Tannous, DiMasi, Masiello, Eppinger. Simon: A simulated injury monitor: Application to head injury assessment.
10. Bradshaw, Morfey. Pressure and Shear responses in brain injury models.
11. Shashi Kuppa. Injury criteria for side impact dummies. May, 2004. National Transportation Biomechanics research center. National Highway Traffic Safety Administration.
12. Pintar, Yoganandan, Baisden. Characterizing Occipital Condyle Loads under High-Speed Head Rotation. *Stapp Car Crash Journal*, Vol 49 (2005) pp. 33-47.
13. Weerappuli, P, Prasad, P. and Barbat, S (2005) 'Effectiveness of the head and neck support device in frontal impacts of CART cars: a CAE analysis', *Int. J. Vehicle Safety*, Vol. 1 Nos. 1/2/3, pp. 129-144.

## **BIO AND CONTACT**

Thomas Green is a senior product development engineer with AmSafe Aviation. He is a graduate from the Northern Arizona University College of Mechanical Engineering, Flagstaff, Arizona. He can be reached at [tgreen@amsafe.com](mailto:tgreen@amsafe.com).

Thomas Bath is Director of Research and Development for AmSafe Aviation. He received his BS in Mechanical Engineering from Colorado State University, and is currently working on his PhD in aircraft impact survivability through Cranfield University. He can be reached at [tbarth@amsafe.com](mailto:tbarth@amsafe.com).

## APPENDIX

Table A1 Current and Proposed Side Facing Injury Criteria

Body Region	EU 96/27/EC	FMVSS-208 (Forward Facing)		FMVSS-214	FMVSS-214 Proposed		FAA Policy
	EuroSID 1	HIII 50M	HIII 5F	US SID 50M	ES-2re 50M	SID-IIsFRG 5F	US SID 50M
Head	HPC = 1000	HIC15 = 700	HIC15 = 700	HIC36 = 1000	HIC36 = 1000	HIC36 = 1000	HIC = 1000
Neck	NA	Nij =1 T = 4170 C= 4000	Nij =1 T = 2620 C= 2520	NA	NA	NA	NA
Chest	D = 42 mm V*C = 1.0 m/s	Chest Ax = 60 g D = 63 mm	Chest Ax = 60 g D = 52 mm	TTI = 85	D = 35-44 mm T12Ax = 82 gs	T12Ax = 82 gs	TTI = 85 Shoulder Belt Tension = 7780 N
Abdomen	abdF = 2.5 kN	NA	NA	NA	Abd F = 2.4-2.8 kN (Total)	NA	No Belt Contact
Pelvis	Pubic F = 6 kN	NA	NA	Ay = 130 g	Pubic F = 6 kN	Iliac+acet F = 5.1 kN	Ay = 130 g
Lower Limbs	NA	Femur F =6.8 kN	Femur F =10 kN	NA	NA	NA	NA

Results Summary Organized by ATD

The results from this test series are described first by the ATD type and then seating location. Results of the EuroSID-1 ATD in the middle seat are provided in Table A2, results in the armrest and wall seating position are provided in Table A3. Results of the Hybrid III ATD are provided in Table A4.

**Table A2 – Data summary of EuroSID-1 peak response values in the middle seat position for lateral impact**

Dummy Type			EuroSID-1	EuroSID-1	EuroSID-1	EuroSID-1
Seat Position			Middle	Middle	Middle	Middle
Type Restraint			Std	AAIR	Std	AAIR
Test Number			F0287	F0331	F0290	F0332
Test Pulse		g's	16.9	17.4	17.9	17.5
Minimum Velocity		ft/sec	45.6	45.1	45	45.1
Head	Ax	g's	-29	-13	-122	41
	Ay	g's	60	31	326	34
	Az	g's	97	28	68	32
	Resultant	g's	112	39	353	44
	HIC		1318	250	2569	263
T1	Ax	g's	-	-23	-	-12
	Ay	g's	-	35	-	35
	Az	g's	-	11	-	13
	Resultant	g's	-	38	-	36
T12	Ay	g's	43	32	48	30
Upper Rib	Dy	inch	0	0	0	0
Middle Rib	Dy	inch	0	0	0	0
Lower Rib	Dy	inch	0	0	0	0.11
Abdomen	sum (3)	lbf	7	19	10	18
Pubic	PSPF	lbf	-697	-450	-875	-451
Web Load	Shoulder	lbf	1332	766	164	716
	Lap	lbf	1160	583	-	603

**Table A3 – Data summary of EuroSID-1 peak response values in the armrest and wall seat position for lateral impact**

Dummy Type		EuroSID-1	EuroSID-1	EuroSID-1	EuroSID-1	EuroSID-1	EuroSID-1	
Seat Position		Armrest	Armrest	Wall	Wall	Wall	Wall	
Type Restraint		Standard	AAIR	Standard	Standard	AAIR	AAIR	
Test Number		F0380	F0379	F0289	G0236	G0235	F0293	
Test Pulse		g's	17.2	16.5	17	15.76	16.6	16.5
Minimum Velocity		ft/sec	45.1	44.6	45.3	45.1	45	45.2
Head	Ax	g's	19	25	-38	-63	-17	28
	Ay	g's	-35	-27	390	43	-32	29
	Az	g's	-53	-25	119	-250	-34	38
	Resultant	g's	65	31	403	261	43	48
	HIC		1016	244	3035	1075	245	296
T1	Ax	g's	25	-31	-	13	-39	-
	Ay	g's	43	32	-	32	36	-
	Az	g's	10	14	-	8	-8	-
	Resultant	g's	44	40	-	34	43	-
T12	Ay	g's	-42	-34	63	-31	33	38
Upper Rib	Dy	inch	0	0.1	1.75	1.59	0.08	0.25
Middle Rib	Dy	inch	0	0.1	1.49	1.14	0.05	0
Lower Rib	Dy	inch	-0.24	0.1	1.3	0.70	0.05	0
Abdomen	sum (3)	lbf	377	19	161	-27	-35	-23
Pubic	PSPF	lbf	-572	-101	-1121	-382	-359	-395
Web Load	Shoulder	lbf	1551	735	415	97	25	744
	Lap	lbf	1777	1710	-	636	750	-

**Table A4 – Data summary of Hybrid III peak response values in the middle, armrest and wall seat position for lateral impact**

Dummy Type			HIII	HIII	HIII	HIII	HIII	HIII
Seat Position			Middle	Middle	Armrest	Armrest	Wall	Wall
Type Restraint			Standard	AAIR	Standard	AAIR	Standard	AAIR
Test Number			F0380	F0379	F0386	F0388	F0290	F0332
Test	Pulse	g's	17.2	16.5	16.8	16.6	17.9	17.5
Minimum	Velocity	ft/sec	45.1	44.6	45	44.5	45	45.1
Head	Ax	g's	36	-16	17	-20	-42	-16
	Ay	g's	-89	-28	24	-30	189	38
	Az	g's	-74	-27	-48	-30	76	-19
	Resultant	g's	97	32	54	37	203	42
Head	HIC		1248	192	597	196	1289	235
Upper Neck	Fx	Lbf	-264	-91	146	-109	-82	-61
	Fy	Lbf	290	105	204	121	363	-90
	Fz	Lbf	750	248	481	321	-543	159
	Resultant	Lbf	815	263	516	344	646	185
Upper Neck	Mx	in-lbf	1083	-243	1901	-263	-711	737
	My	in-lbf	-233	511	-406	654	-130	-256
	Mz	in-lbf	359	-376	953	-330	129	-112
	Resultant	in-lbf	1119	596	2073	722	714	781
Lower Neck	Fx	Lbf	-197	-151	-404	-162	-	-108
	Fy	Lbf	-420	-182	221	-169	-	-147
	Fz	Lbf	-474	304	-255	317	-	196
	Resultant	Lbf	492	330	443	372	-	243
Lower Neck	Mx	in-lbf	3723	535	725	540	-	-345
	My	in-lbf	1022	-532	364	-572	-	680
	Mz	in-lbf	629	-148	293	-176	-	-544
	Resultant	in-lbf	3861	767	820	798	-	769
Chest	Ax	g's	21	16	12	17	32	13
	Ay	g's	-43	26	-33	-31	100	-32
	Az	g's	43	34	-14	-36	20	-22
	Resultant	g's	60	39	35	38	102	33
Web Load	Shoulder	Lbf	1348	780	1248	717	1103	446
	Lap	Lbf	2329	1845	1596	1541	-	100